

# PBX

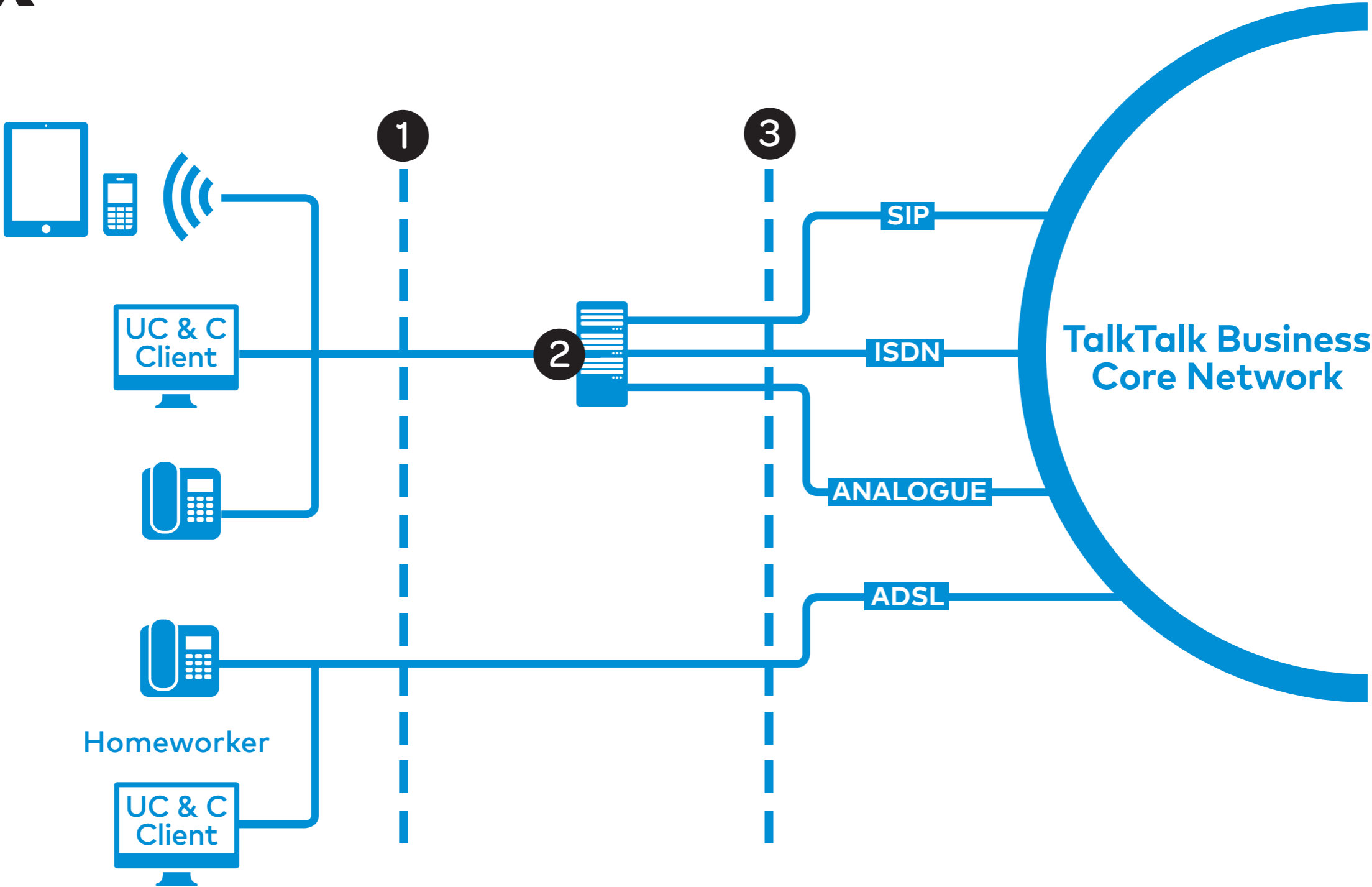

**1** User peripherals  
Multiple devices can be connected to the Telephone exchange to allow users to communicate in the most appropriate way. E.g. IP Phone, PC (via soft-phone), Mobile phone (UC App), Tablet (UC App)

**2** Telephone exchange  
The telephone exchange is a piece of hardware that can be virtualised or situated in the customer premises. It allows calls to be delivered to the right individuals within an organisation and also allows individuals to make calls externally.

**3** Connectivity  
The telephone exchange needs to be connected to the network to enable calls to be made externally. Multiple different types of lines are supported on the telephone exchange.